A black and white photograph of a young child with dark hair, looking out of a car window. The child's hands are resting on the window frame. The background shows a blurred outdoor scene with trees and a bright sky.

BECAUSE EVERY ASSEMBLY IS CRITICAL.



THE QE SERIES

**IR** Assembly Solutions



PRECISION YOU CAN COUNT ON.

Accuracy in the assembly process is crucial, especially when you consider everyone who will rely on those assemblies once they're in place.

And with the new QE Series – it's an attainable goal. The QE Series DC electric nutrunners from Ingersoll-Rand are the first in a new generation of assembly tools that deliver industry-leading accuracy and repeatability – all in smaller, lighter, faster packages.

Coupled with the Insight IC torque control system, QE Series tools employ advanced motor technology to quickly reach specified torque, with easy handling that enhances productivity. The tools' ergonomic design and comfortable front and rear grip surfaces complement the controller's clear displays and intuitive controls to help make operators an integral part of quality assurance.

# PRODUCTIVITY BEYOND PRODUCT

Products such as the QE Series are just one element in Ingersoll-Rand's complete range of Assembly Solutions.

Our offering goes beyond products to include consulting, integration, service, tools and equipment. A total productivity-enhancing portfolio for safe and quality-critical fastening – and all of your assembly processes.



## CONSULTING

- ERGONOMICS
- PLANT AUDITS
- APPLICATION AND PROCESS DESIGN



## PRODUCTS

- FASTENING
- ERGONOMIC HANDLING
- DRILLING
- DISPENSING
- FLUID HANDLING
- MRO TOOLING



## INTEGRATION

- PROGRAM MANAGEMENT
- WORKSTATION DESIGN AND INTEGRATION
- NETWORKED COMMUNICATIONS



## SERVICE

- INSTALLATION
- TRAINING
- REPAIR
- CALIBRATION
- 24/7 TECHNICAL SUPPORT

## Insight™ IC Controller

The Insight IC Controller has been enhanced to take advantage of the latest technology in electronic components, manufacturing processes and circuit design.

All QE Series tools now include a “smart chip” that allows each tool to exchange data about itself and its cycle history with the IC Controller and the user. This information allows the controller to make decisions as to whether the tool is capable of implementing the current fastening configuration called for by the process.

Accessories that provide additional audible and visual cues can be placed in remote locations to indicate status conditions for the operator or supervisor. Other accessories such as socket trays and torque arms build the functionality of the total system. Flexibility in up to forty inputs and outputs allows the Insight IC Controller to connect to even the most complex line control and PLC applications. Multiple communication protocols including serial, parallel, bar code, Profibus and Device Net allow multiple methods of communicating with plant systems, computers and other hardware devices.

## QE Series Tools

The QE Series provides increased usability, accuracy and comfort, with a torque range up to 400 Nm based on three motor sizes. This new tool series incorporates improvements in the areas of:

- **Ergonomics**
  - Lighter
  - Smaller
  - Comfortable grips
  - One handed reverse
- **Productivity/Quality**
  - Faster speeds
  - Improved accuracy
  - Additional options
- **Durability/Maintenance**
  - Improved gear life
  - Improved cable life and flexibility
  - Non-contacting switches
  - Fewer parts



# Product Identification Guides

Available tool configurations include: Angle, straight, push-to-start, offset, tube nut, specials and motor packages. A common design platform allows for common parts across the family.

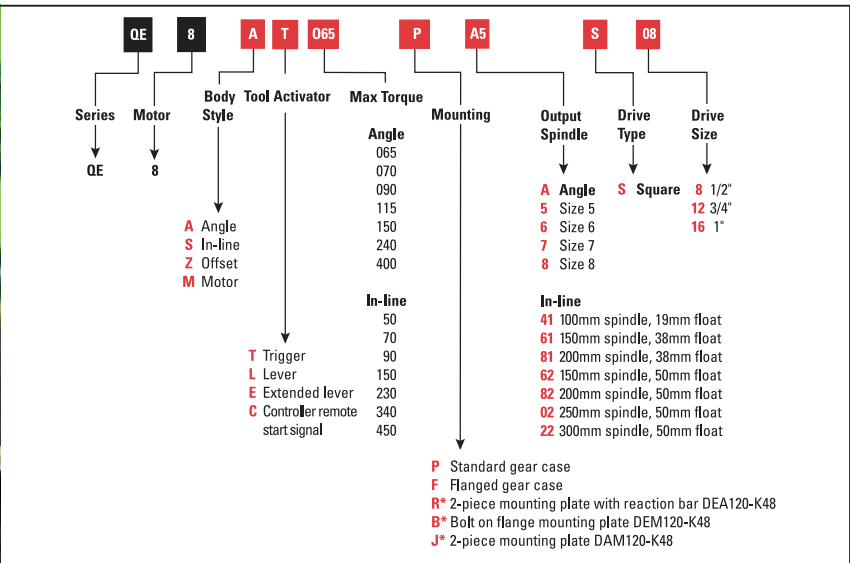
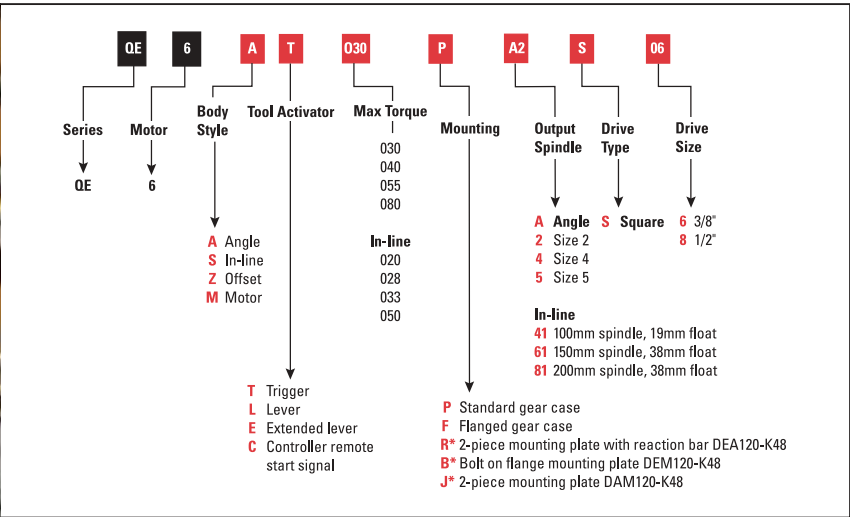
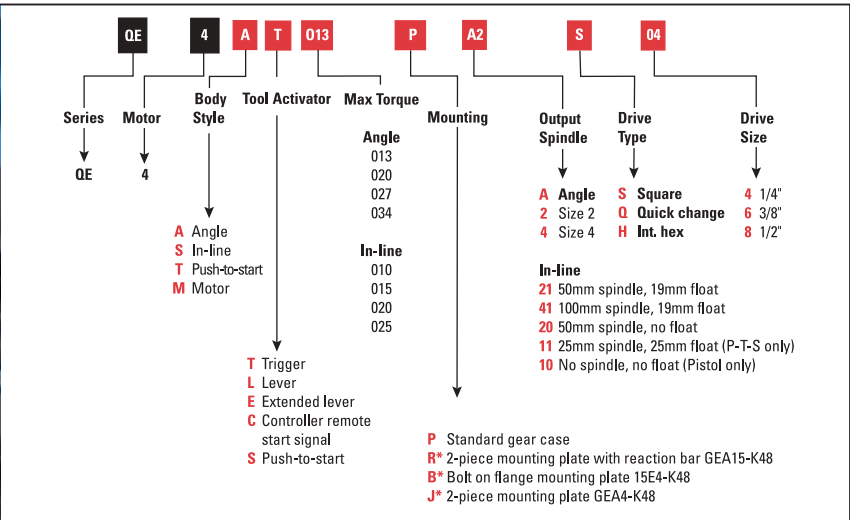

\*Note: See accessories section on page 8 for descriptions.





## Insight IC Controller

- One or two key presses will take you to any screen in the system, providing fast, easy access to data, parameters, statistics and configurations.
- 10.4 inch diagonal color display provides easy viewing from longer distances.
- Large membrane keypad for easy data or parameter entry.

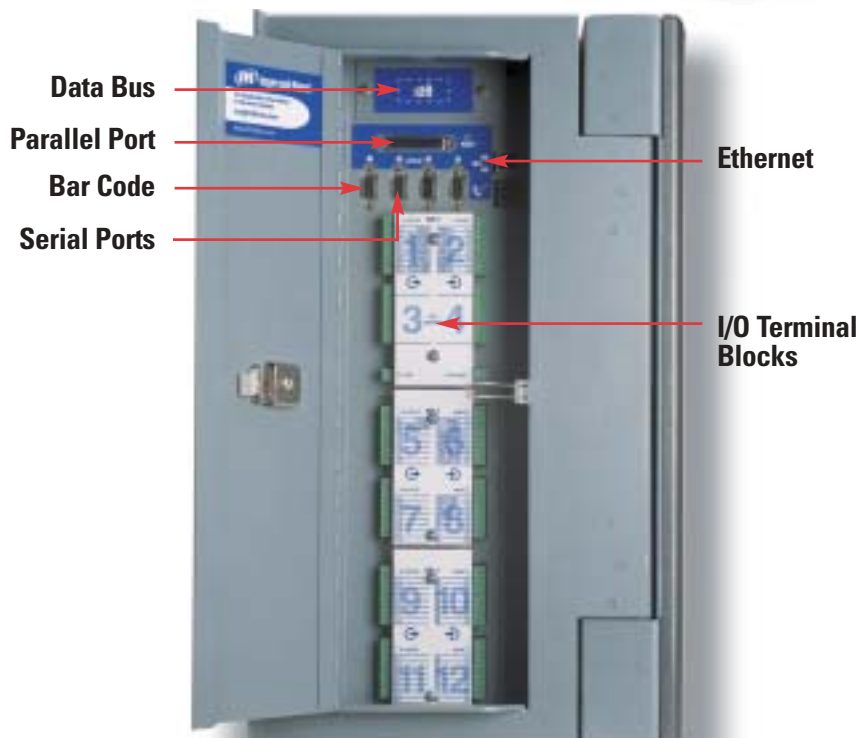

### SPECIFICATIONS

|                |  |
|----------------|--|
| <b>Width:</b>  | 18.7 in.   |
| <b>Height:</b> | 18.5 in.   |
| <b>Depth:</b>  | 10.8 in.   |
| <b>Weight:</b> | Single Spindle: 47 lbs.<br>Dual Spindle: 63 lbs. |

### POWER REQUIREMENTS

120 Volt AC 20 Amp  
230 Volt AC 20 Amp  
CE

**PRODUCT IDENTIFICATION CHART**

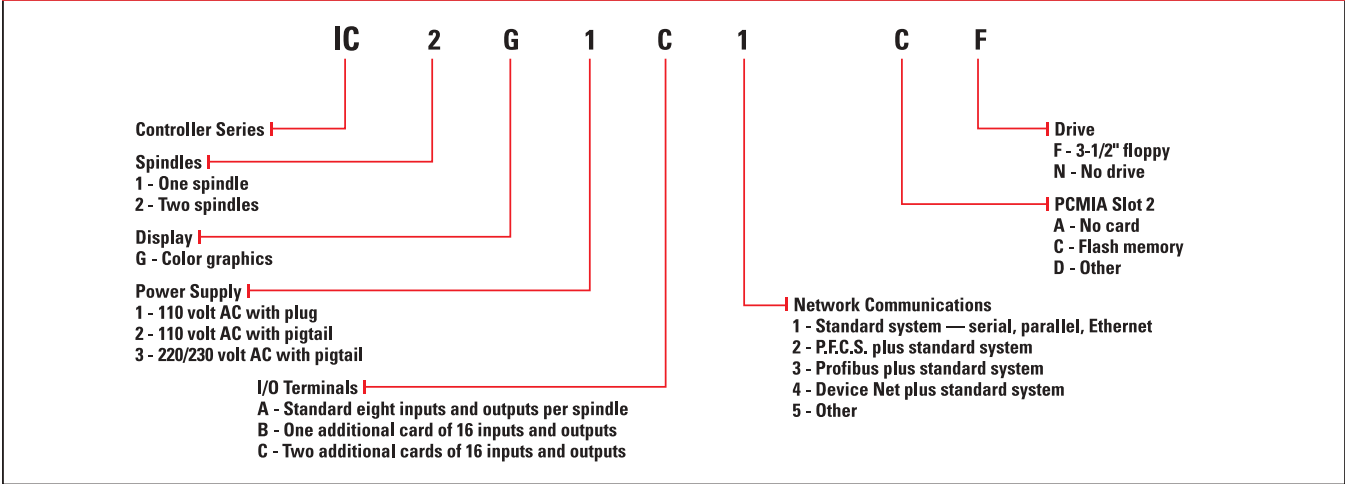

**MAIN MENUS**



**RUN**

- Main** Displays critical information on torque, angle and fastener process status.
- Tightening Curves** Precise graphs on the actual tightening cycle.
- Stats Summary** Actual statistics (CP, CPK,  $\sigma$ ,  $\bar{X}$ , etc.) calculated on your selected sample.
- Cycle Log** Data from selected parameters for last 1,000 cycles.
- View Parameters** Tabular summary of all parameters in fastening configuration.



**STATS**

- Summary** Fastening statistics for either population or sample.
- Export Cycle Log** Select, filter, format and export cycle data via ports or drives.
- Tightening Curves** View, analyze and compare tightening curves against master.
- Cycle Log** View and sort data from the last 5,000 cycles.
- Alarms** Set alarms to detect deviation from selected fastening statistics.



**SET-UP**

- Quick Set-Up** Single step set-up for torque, angle or yield strategies.
- Advanced Set-Up** Program multistep fastening strategies with up to 128 steps.
- Systems Initialization** Load general parameters such as time, date and communication.
- Spindle Initialization** Identify tools or spindles attached to the Insight IC.
- Password and Powerhead Settings** Set password levels and powerhead groups.
- Parameter Transfer** Download or save system's parameter and software.



**DIAGNOSTICS**

- Systems Test** Perform tests and display data from tools and controller.
- Discrete Inputs** Check for presence of signals from up to 40 possible inputs.
- Discrete Outputs** Activate any of the 40 possible output signals.
- Event Log** Display any important Insight IC events that may have occurred.



**PRINT**

- Press Print** Displays and allows printing of reports associated with current screen.



**HELP**

- Press Help** Displays help information for current location and screen.
- Go To Topic** Displays alphabetical listing of help topics.



Tool Cable



90° Tool Cable



Extended Lever



Swivel Hanger Kit



Flanged Mounting Plate



Mounting Plate

---

### TOOL CABLES

|                |                       |
|----------------|-----------------------|
| GEA40-CORD-3M  | 3 Meter Cable (shown) |
| GEA40-CORD-10M | 10 Meter Cable        |

---

### 90° TOOL CABLES

|                   |                           |
|-------------------|---------------------------|
| GEA40-CORD-3M-90  | 3 Meter 90° Cable (shown) |
| GEA40-CORD-10M-90 | 10 Meter 90° Cable        |

---

### EXTENSION CABLES

|               |                          |
|---------------|--------------------------|
| GEA40-EXT-10M | 10 Meter Extension Cable |
| GEA40-EXT-20M | 20 Meter Extension Cable |
| GEA40-EXT-40M | 40 Meter Extension Cable |

---

### LEVER KITS

|             |                    |
|-------------|--------------------|
| GEA40-K98SL | Short Lever Kit    |
| GEA40-K98EL | Extended Lever Kit |

---

### ANGLE HEAD BOOTS

|             |                 |
|-------------|-----------------|
| GEA40-170#2 | Angle Head Boot |
| GEA40-171#4 | Angle Head Boot |
| GEA40-172#5 | Angle Head Boot |
| GEA40-173#6 | Angle Head Boot |

---

### SWIVEL HANGER KIT

|            |                             |
|------------|-----------------------------|
| GEA40-K364 | Swivel Hanger Kit QE6 & QE8 |
|------------|-----------------------------|

---

### SUSPENSION BAIL

|        |                 |
|--------|-----------------|
| 7L-365 | Suspension Bail |
|--------|-----------------|

---

### REACTION BAR KIT

|            |                  |
|------------|------------------|
| GEA15-K48  | QE4 Series       |
| DEA120-K48 | QE6 & QE8 Series |

---

### FLANGED MOUNTING KIT

|            |                  |
|------------|------------------|
| 15E4-K48   | QE4 Series       |
| DEM120-K48 | QE6 & QE8 Series |

---

### MOUNTING PLATE KIT

|            |                  |
|------------|------------------|
| GEA4-K48   | QE4 Series       |
| DAM120-K48 | QE6 & QE8 Series |

# Torque Arms

## PARALLEL TORQUE ARM

|                        |                   |
|------------------------|-------------------|
| <b>Model No.</b>       | <b>IRBP3-E30</b>  |
| <b>Length</b>          | <b>30</b>         |
| <b>Range</b>           | <b>0 to 10 Nm</b> |
| <b>Torque Absorber</b> | <b>Yes</b>        |

## EZ TOOL ARM

|                   |  |
|-------------------|--|
| <b>Part No.</b>   | <b>Description</b>                         |
| <b>EZTA080500</b> | Lightweight torque arm with tool holder    |
| <b>43146000</b>   | Lightweight torque arm without tool holder |

Torque range 0 to 30 Nm

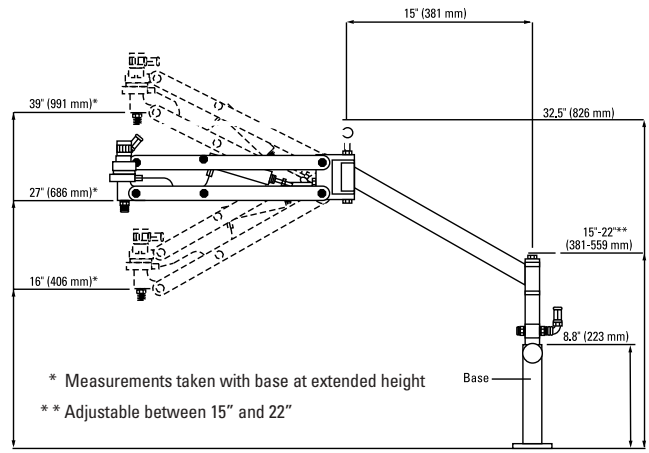

# Torque Tube Features

- Available in 3 torque capacities: 100 Nm, 250 Nm, and 500 Nm
- Modular worldwide metric design
- Super linear bearings for effortless vertical travel and maintenance-free operation
- 60 lb., 60 lb. and 400 lb. capacities
- 4 Delrin wheels for torque reaction and side loading in all four directions
- Adjustable lengths (every 2 inches/50.8 mm) to eliminate the need for extension tubes
- All bolt on assemblies (Tool Holders and Suspension)
- Lightweight construction

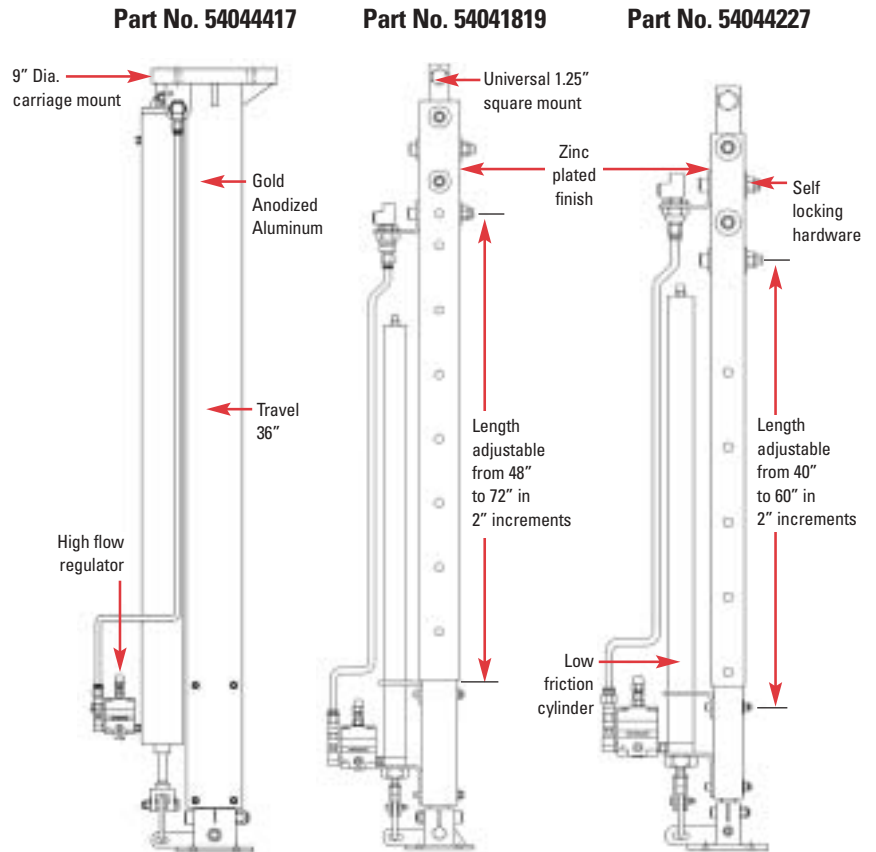
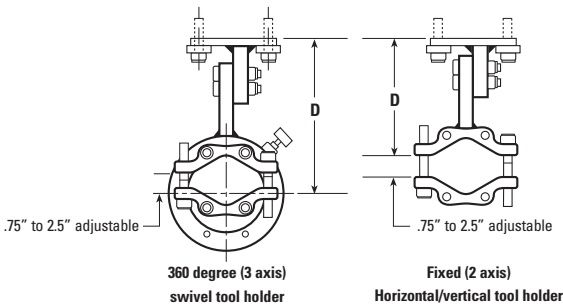

## TOOL HOLDERS FOR IRZ-TT-100 & IRZ-TT-250

| Part No. | Description                    | "D" Dimension |       | Weight |      |
|----------|--------------------------------|---------------|-------|--------|------|
|          |                                | in.           | mm    | lbs    | kg   |
| 52000    | Fixed (2 axis) horiz./vertical | 4.82          | 122   | 2.30   | .90  |
| 52100    | 360 degree (3 axis) swivel     | 5.38          | 136.7 | 5.00   | 2.27 |

Note: IRZ-TT-500 requires custom tool holder.

## TORQUE TUBE

| Part No.                 | Description | Torque Capacity |     | Lift Capacity |                           | Weight |    | Travel |     |
|--------------------------|-------------|-----------------|-----|---------------|---------------------------|--------|----|--------|-----|
|                          |             | ft-lbs          | Nm  | lbs @ 100psi  | lbs @ 7kg/cm <sup>2</sup> | lbs    | kg | in.    | mm  |
| 540044227                | IRZ-TT-100  | 74              | 100 | 60            | 27                        | 40     | 18 | 20     | 508 |
| 540041819                | IRZ-TT-250  | 184             | 250 | 60            | 27                        | 50     | 23 | 24     | 610 |
| 540044417 <sup>1,2</sup> | IRZ-TT-500  | 368             | 500 | 400           | 182                       | 75     | 75 | 36     | 914 |

(1) Carriage mount option only (2) Custom tool holder required – contact factory



**Ingersoll-Rand Company**  
Productivity Solutions  
1467 Route 31 South  
Annandale, NJ 08801  
1-800-376-TOOL

**Ingersoll-Rand Canada**  
51 Worcester Road  
Toronto, Ontario  
Canada, M9W 4K2  
416-213-4500

**Ingersoll-Rand  
Latin America Operations**  
730 NW 107th Avenue, Suite 300  
Miami, FL 33172-3107  
305-559-0500